

NG 2000-5000 User Manual



Contents

Change History	3
How to Use This Manual	3
Introduction	4
Warranties and Liabilities	5
Safety Notices	6
Symbols	6
Safety Notice to Users	6
Declaration of Conformity	7
Environmental Declaration	8
Technical Specification	9
Environment	9
Inlet Conditions	9
Generator Outlets	9
Electrical Requirements	9
General	9
Unpacking	10
Removing the generator from the crate	11
Installation	12
Generator Environment	12
General Dimensions	12
Wall Mounting	13
Electrical Connection	14
Fuse	14
External Connections	14
Start-up Procedure	15
IMPORTANT DOCUMENTS	16
Normal Operation	17
Principal of Operation	17
Unusual Operation	17
Service Requirements	18
Service Schedule	18
Service Plans	18
Cleaning	18

Change History

Rev.	Comment	Name	Date
1	Initial release	S.G.M.	27/11/98
2	System diagrams updated	H.D.	03/04/03
3	USA technical support number added	F.A.D.	11/11/04
4	New style front added	F.A.D.	08/04/05
5	Updated to new format	L.C.	01/10/13
6	Unpacking and Wall Mounting Instructions	L.C.	10/01/14
7			

How to Use This Manual

This manual is intended for end users and has been written so that it can either be read as a step by step guide to installation and usage or as a reference document where you can skip to the relevant information.

Users of a hard copy version can refer to the contents page to find the relevant information. Users of the soft copy version can use the hyperlinks from the contents page as well as the hyperlinks between sections.

Please review each of the following sections carefully.

Thank you for selecting Peak Scientific to meet your Gas Generation needs, and should you require any further assistance or support please do not hesitate to contact Peak Scientific or the Peak Partner from which you purchased your Generator.

Introduction

Welcome to the User Manual for the Peak Scientific high purity Nitrogen gas generator. Enclosed in this manual you will find the information required to ensure that your generator is operated and serviced according to our recommended guidelines, which will prepare you for long and trouble free Nitrogen generation.

The Peak Scientific High Purity Nitrogen Generator is designed specifically for use with laboratory analytical Instruments as a source of carrier gas. The generator has been designed to operate from an existing source of dry, oil free, compressed air, and an electrical supply. To deliver high volume, clean, dry Nitrogen.



Warranties and Liabilities

1. The Company warrants that it has title to the Goods.
2. Subject to the provisions of this clause the Company warrants that the Goods shall comply in all material respects with any specification referred to in the Order Confirmation (as the same may be amended) and shall, subject thereto, be free from defects in material and workmanship for the lesser of a period of twelve months from the date of delivery or thirteen months from the date of dispatch from the factory.
3. Save as provided in this clause and except where the Goods are sold to a person dealing as a consumer (within the meaning of the Unfair Contract Terms Act 1977) all warranties, conditions or other terms implied by statute or common law are hereby expressly excluded save to the extent they may not be lawfully excluded. When the Goods are sold to a consumer within the meaning of the Unfair Contract Terms Act 1977 their statutory rights are not affected by the provisions of this clause.
4. In the event of the Customer making a claim in respect of any defect in terms of clause 2 hereof the Customer must.
 1. Reasonably satisfy the Company that the Goods have been properly installed, commissioned, stored, serviced and used and without prejudice to the generality of the foregoing that any defect is not the direct or indirect result of lack of repair and/or servicing, incorrect repair and/or servicing, use of wrong materials and/or incorrect spare parts
 2. Allow the company to inspect the Goods and/or any installation and any relevant packaging as and when reasonably required by the Company.
5. Subject to the Company being notified of any defect as is referred to in sub-clause 2 hereof within a reasonable time of it becoming apparent and subject always to the terms of sub-clause 4 hereof, the Company shall, in its option, replace or repair the defective Goods or refund a proportionate part of the Price. The Company shall have no further liability to the Customer (save as mentioned in sub-clause 6 hereof).
6. The Company shall be liable to indemnify the Customer in respect of any claim for death or personal injury to any person in so far as such is attributable to the negligence or breach of duty of the Company or any failure by the Company to comply with the provisions of sub-clause 2 hereof.
7. Save as provided in sub-clause 2 hereof the Company shall not be liable in respect of any claim by the Customer for costs, damages, loss or expenses (whether direct, indirect, consequential or otherwise) or indemnity in any respect howsoever arising including, but not by way of limitation, liability arising in negligence (other than pursuant to clause 6 above) that may be suffered by the Customer or any third party.

Safety Notices

Symbols

This manual uses the following symbols to highlight specific areas important to the safe and proper use of the Generator

	A WARNING notice denotes a hazard. It calls attention to an operating procedure, process or similar, which if not correctly performed or adhered to, could cause personal injury or in the worst case death. Do not proceed beyond a WARNING notice until the indicated conditions are fully understood or met.
	A CAUTION notice denotes a hazard. It calls attention to an operating procedure, process or similar, which if not correctly performed or adhered to, could cause damage to the Generator or the Application. Do not proceed beyond a CAUTION notice until the indicated conditions are fully understood or met.
	Caution, risk of electric shock. Ensure power to the Generator has been removed before proceeding.

Safety Notice to Users



These instructions must be read thoroughly and understood before installation and operation of your Peak Generator. Use of the Generator in a manner not specified by Peak Scientific **MAY** impair the **SAFETY** provided by the equipment.



When handling, operating or carrying out any maintenance, personnel must employ safe engineering practices and observe all relevant local health and safety requirements and regulations. The attention of UK users is drawn to the Health and Safety at Work Act 1974, and the Institute of Electrical Engineers regulations.

EU Declaration of Conformity

We Peak Scientific Instruments Ltd.
Of Fountain Crescent, Inchinnan, Renfrewshire, PA4 9RE

Hereby declare that, this declaration of conformity is issued under the sole responsibility of the manufacturer.

Equipment: Nitrogen Gas Generator

Model: NG*000(A) Series *

Denotes any numeric value. (A) Denotes compressor based model.

To which this declaration relates, is in conformity with the following applicable EU Directives, harmonized standards, and other normative requirements.

- **Low Voltage Directive 2014/35/EU**
EN 61010-1: 2010 Safety Requirements for Electrical Equipment for Measurement, Control and Laboratory Use.
- **Electromagnetic Compatibility Directive 2014/30/EU**
EN 61326-1: 2013 Electrical Equipment for Measurement, Control and Laboratory Use - EMC Requirements. (Class A)
- **Restriction on the use of certain hazardous substances in electronic equipment (RoHS) Directive 2011/65/EU as amended by EU 2015/863.**
- **FCC 47 CFR Part 15 class A**
Unintentional radiators; Conducted and Radiated emissions limits.

Signed for and on behalf of Peak Scientific by

Signed: 

Name: Fraser Dunn

Position: Design Engineering Manager
Peak Scientific Instruments Ltd,
Inchinnan, Renfrew, Scotland, PA4 9RE, UK.

Date: 10th August 2021



UK Declaration of Conformity

We Peak Scientific Instruments Ltd.
Of Fountain Crescent, Inchinnan, Renfrewshire, PA4 9RE

Hereby declare that, this declaration of conformity is issued under the sole responsibility of the manufacturer.

Equipment: Nitrogen Gas Generator

Model: NG*000(A) Series *

Denotes any numeric value. (A) Denotes compressor based model.

To which this declaration relates, is in conformity with the following applicable UK Statutory Instruments, Standards and other normative requirements.

- **The Electrical Equipment (Safety) Regulations 2016 (SI 2016 / 1101) as amended.**
BS61010-1:2010 Safety Requirements for Electrical Equipment for Measurement Control and Laboratory Use.
- **The Electromagnetic Compatibility Regulations 2016 (SI 2016 / 1091) as amended.**
BS61326-1:2013 Electrical Equipment for Measurement , Control and Laboratory Use - EMC Requirements.
- **The Restriction of the Use of Certain Hazardous Substances in Electrical and Electronic Equipment Regulations 2012 (SI 2012 / 3032) as amended.**

Signed for and on behalf of Peak Scientific by

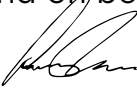
Signed: 

Name: Fraser Dunn

Position: Design Engineering Manager
Peak Scientific Instruments Ltd,
Inchinnan, Renfrew, Scotland, PA4 9RE, UK.

Date: 10th August 2021



WEEE Compliance Statement

The Waste Electrical and Electronic Equipment (WEEE) Regulations SI 2013 No 3113 and or the Waste Electrical and Electronic Equipment (WEEE) Directive 2012/19/EU apply to all electrical and electronic equipment placed on the market in the UK and EU covered by the scope of regulations which can be found in the Government Guidance Notes (PDF) produced by the Department for Business Innovation and skills for the UK and here for Europe.

All PEAK products that are subject to the WEEE directive are compliant with the WEEE marking requirement. Such products are marked with the “crossed-out wheellie bin” symbol (shown below) in accordance with European standard EN50419. All old electrical equipment can be recycled. Please do not dispose of any electrical equipment (including those marked with this symbol) in general rubbish bins. Please contact your dealer or distributor for clarity.

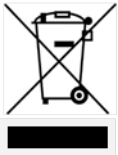

NG Range User Manual

Technical Specification

Environment

Minimum Operating Ambient Temperature	5°C / 41°F
Maximum Operating Ambient Temperature	25°C / 75°F
Maximum Altitude	2000 meters
Maximum Relative Humidity	70%
Minimum Storage Temperature	10°C / 50°F
Maximum Storage Temperature	25°C / 75°F

Inlet Conditions

Minimum Air Pressure	120 psi (8.2 bar)
Maximum Air Pressure	130 psi (8.8 bar)

Generator Outlets

	NG2000	NG3000	NG4000	NG5000
Max Flow Rate (cc/min @ 80 psi (5.5 Bar))	2000	3000	4000	5000
Particles	<0.01µm			
Phthalates	None			
Suspended Liquids	None			
Gas Outlets	1			
Start-Up Time For Purity	8 hours			

Electrical Requirements

Voltage	110/230v
Frequency	50/60 Hz
Current 230v (110v)	0.5 (1.2) A
Pollution Degree	2
Installation Category	II

General

Generator Dimensions cm (")	43 (16.9) x 41 (16.1) x 124 (48.8)			
Generator Weight kg (lbs)	57 (126)	77 (170)	88 (176)	88 (176)
Shipping Crate Dimensions cm (")	64 (25.1) x 60 (23.6) x 146 (57.4)			
Shipping Weight	87 (192)	107 (236)	110 (242)	110 (242)

Unpacking

Although Peak Scientific takes every precaution with safe transit and packaging, it is advisable to fully inspect the unit for any sign of transit damage.

Check 'SHOCKWATCH' label for signs of rough handling prior to un-packing -



Any damage should be reported immediately to the carrier and Peak Scientific or the Peak Partner from where the unit was purchased.

Follow the unpacking instructions posted on the side of the crate. It will require two people to remove the unit from the shipping crate and to manoeuvre the Generator onto the floor.

Please save the product packaging for storage or future shipment of the Generator.

Note: Included with the Generator is a "Fittings Kit" containing a mains power lead for UK, EU or US and all the required fittings. Be careful not to discard these with the packaging.

Removing the generator from the crate

The generator weighs over **57kg** and as such should be unpacked by two people using the following method.

All the screws encircled in **RED** should first be removed from the shipping crate, there are approximately 16 screws, and the front door should then be removed.

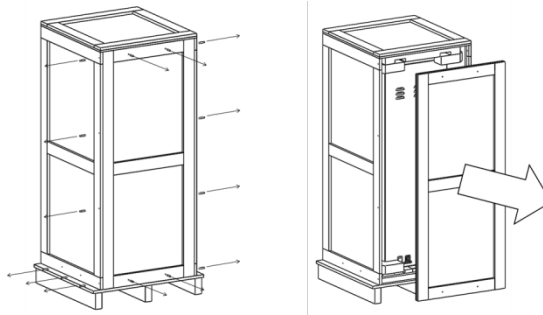

Now, with someone positioned at either side of the shipping crate, the top half of the crate can be slid backwards and away from the rest of the crate. With the top of the crate removed the foam insert of top of the generator should also be taken off.

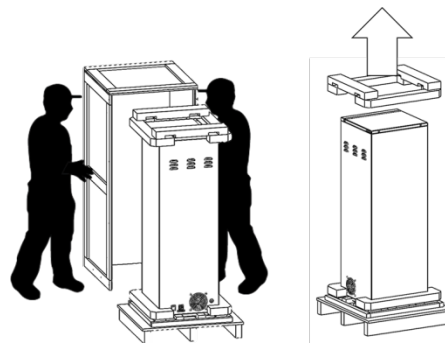

The generator can now be lifted out of the crate base and onto the floor. This should be done again with someone positioned at either side. There is a gap in the foam base for hand access, one hand should be positioned here underneath the generator and the other at the back supporting the weight. The generator should then be tilted back slightly and then up and out of the foam base and onto the floor.

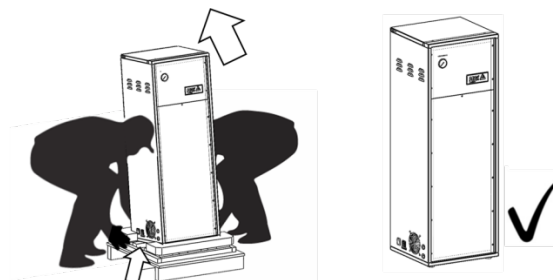

Installation

Generator Environment



The Generator is designed for indoor use only. It should be installed adjacent to the application it is supplying. If this is not convenient then the unit can be sited elsewhere, however, consideration should be made of the lengths of pipe runs as pressure drops can result from extended runs of pipe. Please see the [Tubing lengths](#) section for further details.



Performance of the Generator (like all sophisticated equipment) is affected by ambient conditions. Note should also be taken to the proximity of Air Conditioning outlets. These can sometimes give rise to “pockets” of air with high relative humidity. Operation of the unit within such a pocket could adversely affect its performance. Consideration should also be given to the air flow around the unit. It is recommended that an air gap of 75mm (3”) should be maintained down both sides, at the rear and across the top of the unit. Please refer to the drawing below for the general dimensions of the unit.

Maximum Ambient Conditions: 25°C (dry bulb) 70%RH (Max) Non-Condensing

General Dimensions

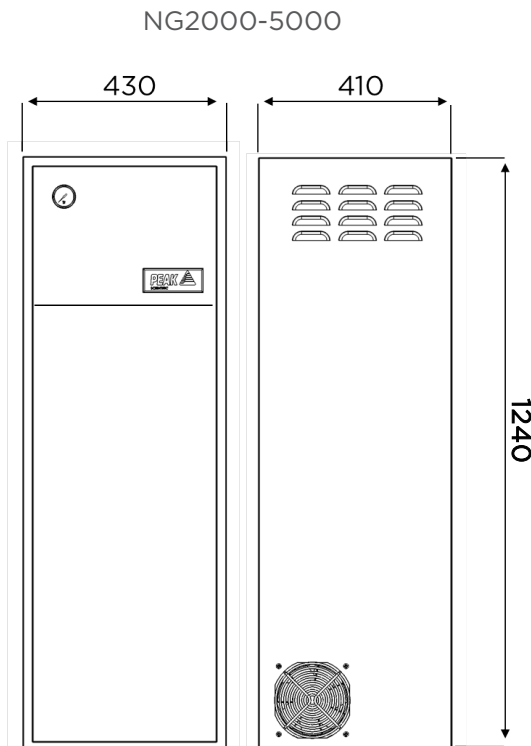

NG Range User Manual

Wall Mounting

The NG range generator is designed to be mounted against a wall for safety reasons.

Supplied in the generator fittings kit are all the fittings required to wall mount the generator. Detailed below are the necessary steps to mount the unit to a wall.

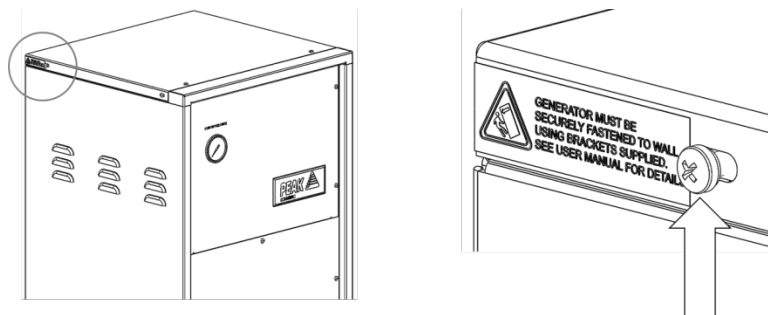

Locate the screw in the top rear corner of the unit, beside the yellow warning label. Remove the screw from the generator this should be repeated for the other side of the unit, and retain.

Next, using the screw which was removed, fit the bracket and washers provided to the generator. Again this should be repeated for the other side. The bracket is adjustable to accommodate varying kickboard widths.

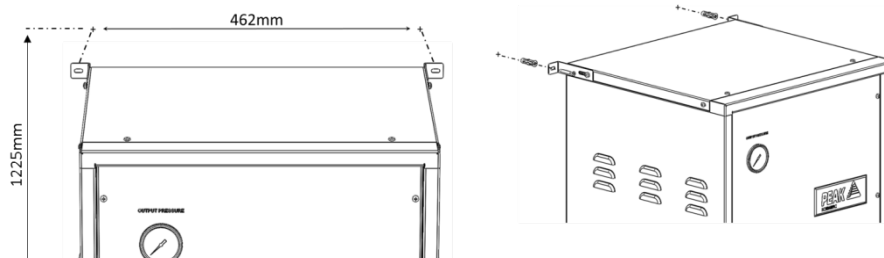

Finally, using the dimensions provided, fix the wall plugs to the wall, ensuring wall plug is suitable for the type of wall. If not, use the correct type. Secure the generator to the wall with the screws from the fittings kit.

Electrical Connection

Connect the Generator to an appropriate 110/230 volt single-phase supply, refer to the generator serial plate for input specification and ensure your supply matches the requirements

If the appropriate power cord is not supplied: a new plug, rated to at least 10 amps, can be fitted by a qualified electrician.



This unit is classified as SAFETY CLASS 1. THIS UNIT MUST BE EARTHED. Before connecting the unit to the mains supply, please check the information on the serial plate. The mains supply must be of the stated AC voltage and frequency.

EARTH/GROUND (E):-	Green & Yellow	or	Green
LIVE (L):-	Brown	or	Black
Neutral (N):-	Blue	or	White

Our electrical requirements are 110/230 VAC nominal +/- 10% depending on chosen model. Extended periods at these extremes can have a detrimental effect on the operation and life of the Generator.

Fuse

The generator protection fuse, in the pull out drawer of the mains inlet IEC connector located adjacent to the off/on switch. The replacement fuse must be rated T10AH250V

External Connections

The Nitrogen Generator should be connected to a clean, dry source of compressed air. A minimum pressure of 120 psi is required. Any doubts as to the suitability of the compressed air supply should be referred to the factory for advice.

The generator has two ¼" BSPT bulkhead connections to the left side of the unit. The upper port is the Compressed Air inlet and the lower is the Nitrogen outlet. A ⅜" Swagelok fitting is supplied for connection to the application. There is no drain on this machine. Any moisture liberated by the filter separator is discharged through the high capacity exhaust system, where sudden reduction in pressure causes instant evaporation. The water vapour is safely removed from the unit by the ventilation system.

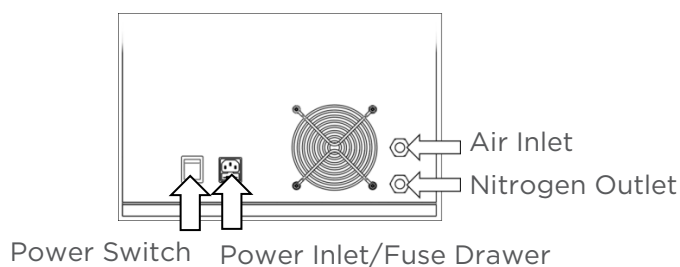

Start-up Procedure

With the generator installed as described earlier, connect power to the unit and turn it on. Disconnect the Nitrogen outlet connection to allow the generator to vent to atmosphere until the unit is stabilised. At Switch-on the exhaust valve will open and the generator will commence its venting cycle. This is to allow venting of any residual pressure in the system. The vent cycle may last up to 90 seconds. At the end of the vent cycle, the inlet valve will open and the normal operating cycle will begin. Pressure should begin to build on the gauge on the front panel, reaching 80 psi after approximately 10 minutes.

The generator has been pre-set in the factory to give the specified output flow rate and pressure. Once the pressure in the Nitrogen receiver exceeds that setting the generator will stabilise and produce pure Nitrogen. Maximum purity will be achieved after around 8 hours. After this time the generator can be reconnected to the application.

The design of the generator is such that it will deliver up to the rated output flow of Nitrogen at 80 psi. Should the demand for Nitrogen be less than the rated output flow, or indeed should the demand stop, the generator will continue to operate without any problems. The generator is protected from over-pressure and its normal operating cycle ensures frequent venting.

IMPORTANT DOCUMENTS



Warranty Entitlement

To register your generator for your warranty entitlement, send the completed form to Peak Scientific by:

- **Email** warranty@peakscientific.com
- **Online** http://www.peakscientific.com/service-and-support/warranty_registration
- **Phone** +44 (0)141 530 4185
- **Fax** +44 (0)141 812 8200

PRODUCT WARRANTY REGISTRATION	
COMPANY:	CONTACT NAME:
ADDRESS:	
	EMAIL ADDRESS:
CITY/TOWN:	GENERATOR SERIAL NUMBER:
POSTCODE:	
COUNTRY:	MODEL TYPE:
TELEPHONE:	INSTALLATION DATE (DD/MM/YYYY):

Important Please Note:

You have 1 month to register your Peak Scientific product from the date of shipment.

If you wish to defer installation of your generator you must notify Peak Scientific within 1 month of the shipment date. This can be done by emailing warranty@peakscientific.com Once registered the warranty will be honoured for a period of 12 months after the installation date.

For any generators that remain unregistered the warranty will begin from date of shipment.

Thank you on behalf of Peak Scientific.

Normal Operation

Principal of Operation

The High Purity Nitrogen Generator utilizes a 'Pressure Swing Adsorption' (PSA) method to extract pure Nitrogen from air. This is where un-wanted gasses can be selectively adsorbed from compressed air into a porous carbon molecular sieve material (CMS). The Peak Scientific Instruments LTD. Generator utilizes a unique single column system where the column is alternately pressurised and vented under a finely tuned timing cycle. The rates of pressurisation and venting are accurately set which guarantees high purity better than can be achieved with a similarly sized traditional 2-column system.

Unusual Operation

If at any time the Generator begins to emit excessive noise or vibration, then it should be switched off and you should contact Peak Scientific or the Peak Partner from which the Generator has been purchased.

Service Requirements

Service Schedule

Service Interval	Component	Part No.	Qty.
12 months	Separator filter element	02-4335	1
	Exhaust silencer element	02-4336	1
	Silencer filter	02-1016	1

Table 1: Service schedule

As an alternative to purchasing the 12 month service items individually an Annual Service Kit is available as one part number. This contains all the filters required for this Generator and offers a costs saving over buying the components separately.

Purchase Interval	Component	Part No.	Qty.
12 months	Service Kit NG250-5000	08-4723	1

Service Plans

Peak Scientific offer two service plans. The Complete Service Plan, specifically designed for Generators operated in critical environments, also includes full breakdown cover, guaranteed response times and Generator upgrades if available. Our Standard Service Plan, covering the basic needs of our Generators, features special deals on spare parts and breakdowns.

If you want to know more about our Service Plan options and how we ensure that your instrument can run with the maximum uptime and performance, please contact us at maintenance@peakscientific.com

Cleaning

Clean the outside of the Generator only using warm soapy water and a clean damp cloth. Ensure the cloth is thoroughly rung out to remove excess fluid prior to use.



Cleaning should only be undertaken with the power switched off and the power cord removed from the rear of the Generator.



Under no circumstances should any solvents or abrasive cleaning solutions be used as these can contain fumes that could be harmful to the Generator.

Peak Scientific UK

Fountain Crescent
Inchinnan Business Park
Inchinnan
PA4 9RE
Scotland, UK

Tel: +44 (0)141 812 8100
Fax: +44 (0)141 812 8200

Peak Scientific Germany

Herriotstrasse 1
60528 Frankfurt

Germany

Tel: +49 (0)69 677 33 490
Fax: +49 (0)69 677 33 200

Peak Scientific Taiwan

4F.-6, No.736
Zhongzheng Rd.
Zhonghe Dist.
New Taipei City

Tel: +886 2 8226 2383
Fax: +886 2 8226 9499

Peak Scientific North America

19 Sterling Road
Suite #1
Billerica, MA 01862

USA

Tel: +1 866 647 1649
Fax: +1 978 608 9503

Peak Scientific China

Room 606 Building 1
Lane 2277 Zuchongzhi Road
Pudong New Area
Shanghai
201203, China

Tel: +86 21 5079 1190
Fax: +86 21 5079 1191

Peak Scientific Brazil

Peak Scientific Brasil
Av. Quieroz Filho
1700 - torre Sunny-Conj. 602
São Paulo SP Brasil

Tel: +1 866 647 1649

Peak Scientific India

202, Amsri Shamira
Old Lancer Line
Opp. St. Mary's Degree College
S.D. Road Secunderabad
500 025, India

Tel: +91 40 2780 0663
Fax: +91 40 2780 0663

Peak Scientific Mexico

Solon 352
Col. Los Morales Polanco
11530 Mexico, D.F.

Mexico

Tel: +1 866 647 1649
Fax: +1 978 608 9503

Peak Scientific Japan K.K.

2-7-56, 2F Fuji Building 28
Kita Aoyama, Minato-Ku
Tokyo, Japan
107-0061

Tel: +81 3-6864-0468

Peak Scientific Africa

PO Box 478
Somerset Mall
7137

South Africa

Tel: +27 (0)2185 16542
Fax: +27 (0)8654 64473

Peak Scientific Australia

PO Box 65
Belmont
Victoria 3216

Australia

Tel: +61 1300 965 352

Peak Scientific Singapore

3 Science Park Drive
#03-14 The Franklin
Science Park Drive 1
Singapore, 118223

Tel: +65-6777 1966
Fax: +65-6777 1978