

Nitrogen N*10DR Nitrogen Generator



User Manual UM – N*10DR – Rev 4



Peak Scientific Instruments Ltd.

www.peakscientific.com

UK

Fountain Crescent
Inchinnan Business Park
Inchinnan
Renfrew PA4 9RE
Scotland
UK

Tel. +44 (0) 141 812 8100
Fax. +44 (0) 141 812 8200
info@peakscientific.com

USA

19 Sterling Road
Unit 5B
Billerica
MA 01862
USA

Tel. +1 866 647 1649
Fax. +1 781 275 5651
usasupport@peakscientific.com

Contents

Contents

	Page
Contents	2
Document Change History	3
Warranty Statement	4
Safety Notice to Users	4
RoHS Compliance Statement	5
WEEE Compliance Statement	5
Technical Specification	6
Introduction	7
Unpacking and Installation	8
Removal of Transit Bracket	9
Useful Information	10
Electrical Connection	10
Generator Environment	11
General Dimensions	11
Generator Connections	12
Generator Controls	12
Operation	13
Control Panel / Fault Diagnosis	14
Additional Points to Note	15
Routine Maintenance	16
Maintenance Log	17

History

Document Change History

Rev No.	Change	Initials	Date
1	First Release	G.L.	16.10.06
2	Notes added for - Indoor use only & Altitude	T.G.	10.09.07
3	Update USA address	S.K	25/08/2008
4	Updated solenoid valve part #	S.K	26/01/2009

Warranties & Liabilities

1. The Company warrants that it has title to the Goods.
2. Subject to the provisions of this clause the Company warrants that the Goods shall comply in all material respects with any specification referred to in the Order Confirmation (as the same may be amended) and shall, subject thereto, be free from defects in material and workmanship for the lesser of a period of twelve months from the date of delivery or thirteen months from the date of dispatch from the factory.
3. Save as provided in this clause and except where the Goods are sold to a person dealing as a consumer (within the meaning of the Unfair Contract Terms Act 1977) all warranties, conditions or other terms implied by statute or common law are hereby expressly excluded save to the extent they may not be lawfully excluded. When the Goods are sold to a consumer within the meaning of the Unfair Contract Terms Act 1977 their statutory rights are not affected by the provisions of this clause.
4. In the event of the Customer making a claim in respect of any defect in terms of clause 2 hereof the Customer must:-
 - 4.1. reasonably satisfy the Company that the Goods have been properly installed, commissioned, stored, serviced and used and without prejudice to the generality of the foregoing that any defect is not the direct or indirect result of lack of repair and/or servicing, incorrect repair and/or servicing, use of wrong materials and/or incorrect spare parts; and
 - 4.2. allow the company to inspect the Goods and/or any installation and any relevant packaging as and when reasonably required by the Company.
5. Subject to the Company being notified of any defect as is referred to in sub-clause 2 hereof within a reasonable time of it becoming apparent and subject always to the terms of sub-clause 4 hereof, the Company shall, in its option, replace or repair the defective Goods or refund a proportionate part of the Price. The Company shall have no further liability to the Customer (save as mentioned in sub-clause 6 hereof).
6. The Company shall be liable to indemnify the Customer in respect of any claim for death or personal injury to any person in so far as such is attributable to the negligence or breach of duty of the Company or any failure by the Company to comply with the provisions of sub-clause 2 hereof.
7. Save as provided in sub-clause 2 hereof the Company shall not be liable in respect of any claim by the Customer for costs, damages, loss or expenses (whether direct, indirect, consequential or otherwise) or indemnity in any respect howsoever arising including, but not by way of limitation, liability arising in negligence (other than pursuant to clause 6 above) that may be suffered by the Customer or any third party.

Caution

SAFETY NOTICE TO USERS

These instructions must be read thoroughly and understood before installation and operation of your Peak N*10DR generator. Use of the generator in a manner not specified by Peak Scientific MAY impair the SAFETY provided by the equipment.

When handling, operating or carrying out any maintenance, personnel must employ safe engineering practices and observe all relevant local health and safety requirements and regulations. The attention of UK users is drawn to the Health and Safety at Work Act 1974, and the Institute of Electrical Engineers regulations.

Declaration of Conformity



RoHS Statement of Compliance

The European RoHS (Restriction of Hazardous Substances) Directive 2002/95/EC aims to reduce the use of hazardous materials within a certain scope of products – mostly electrical and electronic.

Peak Scientific Instruments Ltd has developed all reasonable 'due diligence' controls, to ensure that our products comply with the principles, and requirements, of this directive. Similar directives in the United States and China, for example, have also been captured within this programme.

Where a specific certificate of compliance is required, this can be requested, on a product serial number basis, from Peak Scientific Instruments Ltd, by contacting us through info@peakscientific.com.



WEEE Statement of Compliance (WEE/FJ0116XU)

The WEEE (Waste of Electrical & Electronic Equipment) Directive 2002/96/EC, issued by the European Union, aims to reduce the impact, upon the environment, from disposal of certain types of equipment. It requires producers to implement controls, to ensure that equipment that they produce, is correctly disposed of, following the end of its useful life.

Peak Scientific Instruments Ltd fully complies with it's obligations towards this important legislation. These obligations refer to all electrical equipment that has been dispatched by us from 1st July, 2007, within the United Kingdom. As part of our compliance towards this, we have placed the management of this disposal with the B2B Compliance scheme. They can be contacted directly on 01691-676124, or by visiting their website on www.b2bcompliance.org.uk.

Ken Brown
Quality Assurance Manager

Technical Specification

Generator Environment	
Minimum operating ambient temperature	5°C (41°F)
Maximum operating ambient temperature	25°C (77°F)
Maximum relative humidity	70%
Maximum Altitude	2000 Meters
Nitrogen Outlet	
Maximum flow	30 l/min (1.1 CFM)
Maximum Pressure	6.89 bar (100 psi)
Particles	< 0.01 µm
Outlet 1/4" BSP	1
Pressure Gauges	1
Pthalates	None
Suspended Liquids	None
Electrical Requirements	
230V (50/60 Hz)	8.4 amps
Compressor fuse on Control PCB	8.0 amps
PLC / fan fuse on Control PCB	2.0 amps
Electrical connection	Single phase power cord
Noise Level	57dBA @ 1m
General	
Dimensions in cm (inches) W x D x H	94.5 x 59 x 70.7 (37 x 23 x 28)
Weight	145 kg (319 lb)
Shipping weight	190 kg (419lb)

Introduction

Welcome to the User Manual for the Peak Scientific N*10DR Nitrogen Generator. Enclosed in this manual you will find the information required to ensure that your generator is operated & serviced according to our recommended guidelines which will prepare you for long and trouble free Nitrogen generation.

Please review each of the following sections carefully and ensure that the maintenance log at the rear of this manual is updated for future reference.

Thank you for selecting Peak Scientific to meet your gas generation needs, and should you require any further assistance or support please do not hesitate to contact us at the addresses displayed on the front cover of this manual.

Unpacking and Installation

Unpacking and Installation

Although Peak Scientific takes every precaution with safe transit and packaging, it is advisable to fully inspect the unit for any sign of transit damage.

Check 'SHOCKWATCH' label for signs of rough handling prior to unpacking -



ANY DAMAGE SHOULD BE REPORTED IMMEDIATELY TO THE CARRIER AND PEAK SCIENTIFIC OR THE DISTRIBUTOR FROM WHERE THE UNIT WAS PURCHASED.

Follow the un-packing instructions posted on the side of the crate. It will require two people to lift the crate clear and to manoeuvre the generator onto the floor.

Installation

Removal of Transit Bracket

Remove Rear Panel as follows:-

At the rear of the unit, turn the key in the lock anti-clockwise to unlock the rear panel. Hold the rear panel by the two handles and slowly swivel the bottom of it out and lower it until the top comes free from the chassis. Disconnect the plug at the LHS so that the rear panel can be completely removed.

Disassemble Transit Bracket as follows –

- Remove Screw **1** holding two pieces of transit bracket together.
- Remove Screws **2,3,4,5**, holding the Transit Bracket to the Compressors
- Remove Screws **6,7** holding the Bracket to the internal side panels.
- Remove transit bracket from unit.

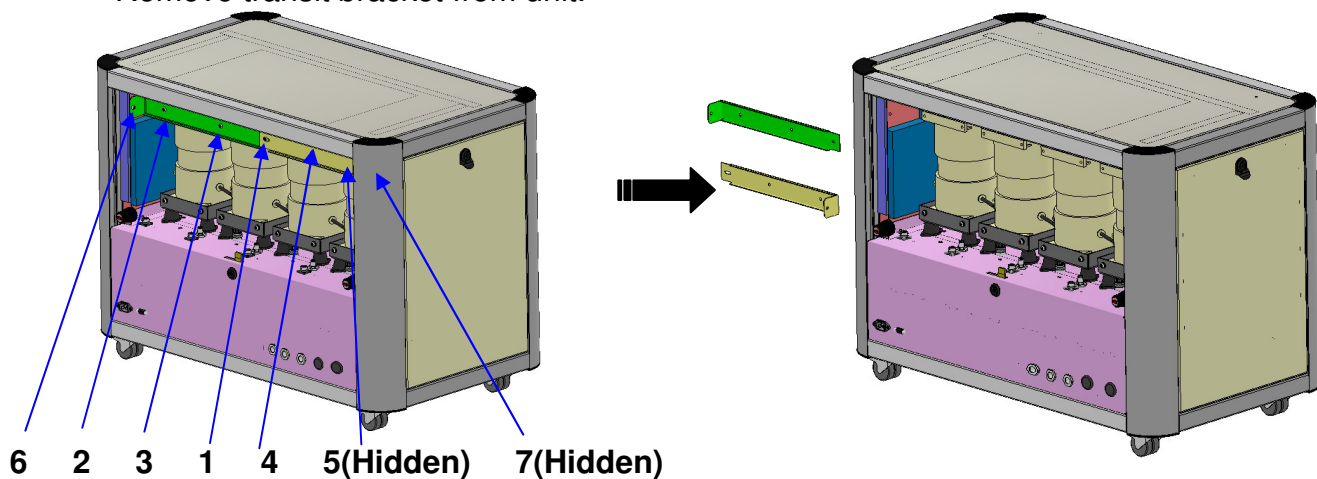

Re-fit the rear panel in reverse order of removal.

Important Note:

The Transit Bracket must be removed prior to switching the unit on. Failure to do so will result in damage to the equipment.

The Generator can now be moved to its final location on the castors provided.

Note: - Included with the Generator is a pack containing hex key, manuals, fittings. Be careful not to discard these with the packing.

Please save the product packaging and Transit Bracket for storage or future shipment of the compressor.

Installation

Useful Information

The diameter of the tubing which will be connected to the gas outlets is important and is determined by the length of tubing required. Failure to follow these recommendations could lead to accelerated compressor wear.

< 10 meters.	Use 6/4 (6mm O/D, 4mm I/D) P.T.F.E. tubing.
> 10 - 40 meters.	Use 10/8 (10mm O/D, 8mm I/D).
> 40 metres.	Please contact Peak with the relevant distance and we will calculate the flow resistance and the tubing size required.

A combination of 6/4 and 10/8 tubing may be used to ensure that there is no large diameter tubing within the lab (i.e. for the first 10 meters use 6/4 tubing and the final 20 meters use 10/8).

Keep the connections and bends to a minimum.

The imperial equivalents are:-	6/4 = 1/4" O/D, 3/16" I/D.
	10/8 = 3/8" O/D, 5/16" I/D.

Caution

Electrical Connection

Important Electrical Notice

This unit is classified as **SAFETY CLASS 1** equipment. **THIS UNIT MUST BE EARTHED.** Before connecting the unit to the mains supply, please check the information on the serial plate. The mains supply must be of the stated AC voltage and frequency.

The Electrical requirement is:-	230V AC (50/60 Hz), 8.4 Amps
---------------------------------	------------------------------

EARTH/GROUND (E):-	Green & Yellow	or	Green
LIVE (L):-	Brown	or	Black
Neutral (N):-	Blue	or	White

Connect the compressor to a single-phase supply using the power cord provided.

Generator Environment

The Generator is designed for indoor use only.

The unit should be installed adjacent to the Mass Spectrometer it is supplying. If this is not convenient then the unit can be sited elsewhere, however, consideration should be made of the lengths of pipe runs as pressure drops can result from extended runs of pipe. Please see the “Useful Information” section for further details.

Performance of the generator (like all sophisticated equipment) is affected by ambient conditions. Note should also be taken to the proximity of Air Conditioning outlets. These can sometimes give rise to “pockets” of air with high relative humidity. Operation of the unit within such a pocket could adversely affect its performance. Consideration should also be given to the air flow around the unit. It is recommended that an air gap of 75mm (3”) should be maintained down both sides, at the rear and across the top of the unit. Please refer to the drawing below for the general dimensions of the unit.

Maximum Ambient Conditions: 25°C (dry bulb) 70%RH (Max)

General Dimensions

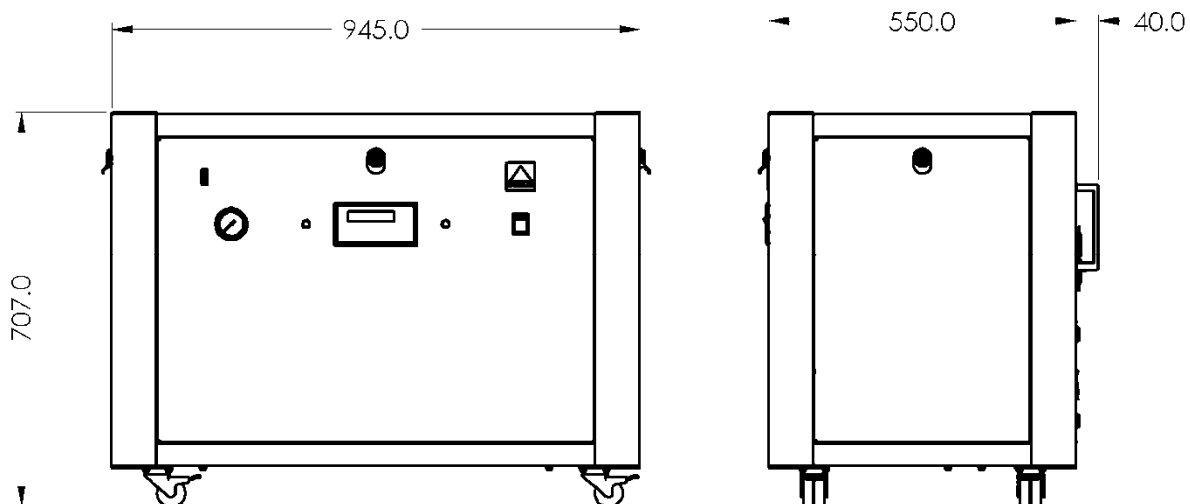

Unit must always be placed on a level surface. Failure to do so will effect the performance of the Generator.

Connections

Connections to Rear of Unit

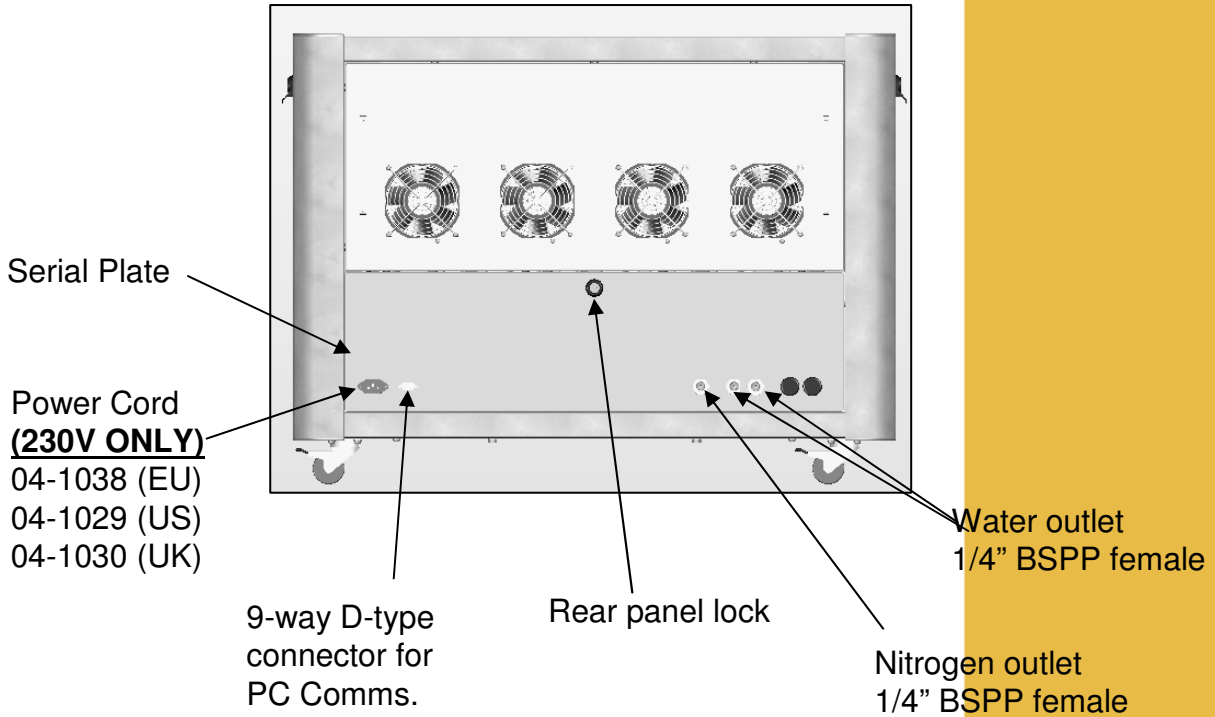

Generator Controls

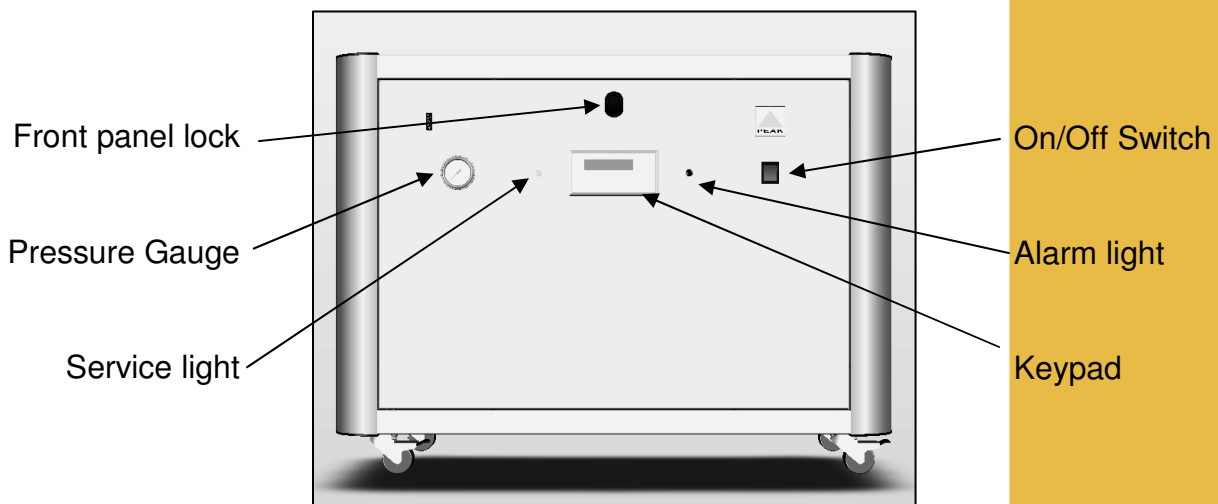

Operation

The N*10DR generator is designed specifically to minimize operator involvement. Given that the system is installed as described in earlier sections and is serviced in accordance with the following maintenance recommendations then it should simply be a matter of turning the generator on. The generator will automatically produce the factory default flow and pressure.

Start Up Sequence When the unit is switched on the fans should power up and the display on the front panel should read –

Compressor Test

The system will now run through an automatic compressor check procedure. Each of the four compressors is tested in turn to ensure that it is working. The compressor check takes a minute or so and then the system will turn on fully and “PLEASE WAIT” will be displayed while pressure builds. The pressure can be monitored on the front panel gauge.

Gas Generation When the system is running, the maximum number of compressors operating at any time is two. To ensure the longevity of the system, the compressors cycle in pairs, with a pair running for a three minutes while the other pair are turned off to cool, then the running pair are switched off to cool and the idle pair are switched on. The display will read -

Peak Scientific
Mode: APCI

***Note: The outlet should be vented to atmosphere for at least 30 seconds to purge the system of impurities.**

If only a small volume of gas is being drawn from the system, it will automatically change into ESI mode. The display will read -

Peak Scientific
Mode: ESI

Whilst running in this mode, if too much gas is then being drawn from the system, it will automatically change into APCI mode to meet the increased demand.

The user can manually select ESI or APCI Compressor mode by pressing the relevant button on the control panel. If ESI mode is selected while the system requires two compressors, it will automatically return to APCI mode.

ESI

APCI

Operation

Control Panel / Fault Diagnosis

If there is a problem with the system, the user will be informed by one of the two available indicators -

SERVICE : Audible buzzer and light on the front panel

ALARM : Audible buzzer and light on the front panel.

To stop the audible buzzer press  on the Control Panel. Note the light will stay illuminated as long as the unit has power.

Interrogating the Control Panel to find fault -

Diagnostic: To display the current status of each compressor, the system and the inlet filter. The compressors are numbered 1 to 4 from the right-hand side looking from the rear and are identified by holes in the panel they are sitting on.

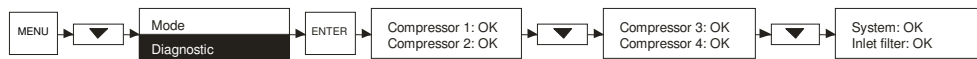

To exit.



Operating hours: To display the current operating hours of each compressor / membrane in hours and minutes.



To exit.



System hours: To display the time since the last service and the total system operating time in days.



To exit.



To display the software revision.

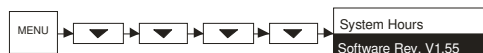

To exit.



Mode: To display the current operating mode.



Additional Points

Additional Points to Note

Pressure / Flow Adjustment

The system is configured in the factory to give standard Outlet Pressure and Flow Rate (see 'Technical Specification' page 6). **These settings should NEVER require adjustment during normal operation.** During service/fault diagnosis the settings can be changed by adjusting the pressure regulator and flow controller situated on the Electrical Panel (see page 18). Both will be in the locked position on receipt of the unit. To unlock and reset the following steps should be completed –

Pressure Regulator

- Pull adjustment knob upwards away from the bracket to release the lock.
- Rotate to increase/decrease pressure.
- Push adjustment knob downwards towards the bracket to lock.

Flow Controller

- Rotate knurled locking nut at base of adjustment knob to release lock.
- Rotate to increase/decrease flow.
- Rotate knurled locking nut at base of adjustment knob to lock.

Unusual Operation

If at any time the generator begins to emit excessive noise or vibration, then it should be switched off and you should contact your local representative or Peak Scientific as soon as possible.

System Drain

Please ensure that the drain port at the rear of the generator is led to a suitable connection or container make sure the container is not sealed tight. It should be noted that the generator will expel considerable amounts of water from this port. If a container is used it should be emptied at regular intervals.

Service

Ensure that the generator is serviced in accordance with the maintenance recommendations.

Maintenance

Routine Maintenance

WARNING

Servicing and/or repair of the Generator should only be undertaken by a **TECHNICALLY COMPETENT PERSON**, with the generator in its safely isolated condition.

SAFELY ISOLATED CONDITION

Definition: The unit is in a Safely Isolated Condition when it is disconnected from its application, fully de-pressurised and isolated from the Electrical Supply. Directions for isolating the generator are shown below.

Isolating the Generator:

- a) Switch off the unit.
- b) Unplug the generator from the mains supply and remove the power cord from the rear of the unit.
- c) Ensure the pressure gauge on the front panel reads zero. (If gauge does not fall to zero, loosen outlet fitting slightly to allow trapped gas to escape.)
- d) Disconnect from the application.
- e) **Important Note:** Allow 10 minutes for unit to fully de-pressurise. After this time pull out the 'Quick Release Ring' on the Pressure Relief valve situated on the tank. Ensure tank is fully depressurised before releasing the ring.

Maintenance Schedule

SERVICE INTERVAL	COMPONENT	PART NO.	
1 YEAR	ELIMINISER FILTER (x1)	02-4366	
	COALESCER FILTER (x1)	02-4364	
	FLOAT ASSEMBLY VALVE (x2)	02-4464	
	RAC Filter (x1)	00-4425	
1 YEAR OR ON SYSTEM ALARM	INLET FILTER (x1)	02-1054	
ANNUAL SERVICE KIT	INCLUDING ABOVE	(08-4714)	
2 YEARS	SOLENOID VALVE 2/2 G1/8" N.C 2.4mm (x1)	02-4692	
	SOLENOID VALVE 2/2 G1/8M N.O 1.6mm (x2)	02-6000	
	COMPRESSOR ASSEMBLY (x4)	08-8069	
ALTERNATIVE TO COMPRESSOR ASSEMBLY	COMPRESSOR RE-FIT (x4)*	06-5529	On Request

*Compressors can be re-fitted as an alternative to replacement up to a maximum of 3 times, this is a more cost effective solution, however a degree of technical expertise is required and can be time consuming.

Maintenance Log

Maintenance Log for Serial Number _____

Work Done	Remarks	Name	Date