

Genius 3070
User Manual



Contents

Change History	4
How to use this Manual	4
Introduction	5
Warranties and Liabilities	6
Safety Notices	7
<i>Symbols</i>	7
Safety Notice to Users	7
EU Declaration of Conformity	8
UK Declaration of Conformity	9
WEEE Compliance Statement	10
Technical Specification	12
Environment	12
Generator Outlets	12
Electrical Requirements	12
General	12
Unpacking	13
Installation	14
Generator Environment	14
General Dimensions	14
Fittings Kit	15
Removal of Transit Brackets	16
Unit Controls	17
Rear Connections	17
Drain Connection	18
Electrical Connection	19
Initial Purge Run	21
Connecting to the Application	22
Tubing Lengths	22
IMPORTANT DOCUMENTS	23
Normal Operation	24
On Demand Air	24

Generator Cycling	24
Unusual Operation	24
Service Requirements	25
Service Schedule	25
Service Indication	25
Stage 2	26
Service Indication Reset	26
Service Plans	26
Cleaning	26
High Duty Indication	27
High Duty Indication Reset	27
Indication of Fault	27
Trouble Shooting	28

Change History

Rev.	Comment	Name	Date
1	Update to Gas Description	Liam Couttie	04/07/13
2	Capacitor Change	Liam Couttie	19/03/14
3	Declarations Update	Liam Couttie	17/11/21

How to use this Manual

This manual is intended for end users and has been written so that it can either be read as a step by step guide to installation and usage or as a reference document where you can skip to the relevant information.

Users of a hard copy version can refer to the contents page to find the relevant information. Users of the soft copy version can use the hyperlinks from the contents page as well as the hyperlinks between sections.

Please review each of the following sections carefully.

Thank you for selecting Peak Scientific to meet your Gas Generation needs, and should you require any further assistance or support please do not hesitate to contact Peak Scientific or Peak Partner from which you purchased your Generator.

Introduction

The Genius 3070 has been developed to cater for systems which require a source of Dry Air (Nebulizer/Heating Gas) and Air (Exhaust).

Further features include:

- Quiet in operation – noise level of 54 db(A)
- Anti- vibration – maximum reduction of vibration
- Service indication – allowing you to plan your maintenance and keep your application uptime at a maximum
- Improved drainage – reduction of moisture carry over and thus increased reliability
- Re- heat technology – improves membrane performance and reliability
- Robust control system – improves safety and reliability of units

With the Genius 3070 based on proven technology, it removes moisture and other gases to leave clean, dry, phthalate free Air. Internal air compressors make this unit independent from in- house air supplies and fitted castors allow the user to easily position the unit in the lab.

To ensure this Generator model meets our high expectations with regards to reliability and performance, we have tested this new model extensively at our manufacturing plant and with end users around the world to ensure reliability and longevity of the system.



Warranties and Liabilities

1. The Company warrants that it has title to the Goods.
2. Subject to the provisions of this clause the Company warrants that the Goods shall comply in all material respects with any specification referred to in the Order Confirmation (as the same may be amended) and shall, subject thereto, be free from defects in material and workmanship for the lesser of a period of twelve months from the date of delivery or thirteen months from the date of dispatch from the factory.
3. Save as provided in this clause and except where the Goods are sold to a person dealing as a consumer (within the meaning of the Unfair Contract Terms Act 1977) all warranties, conditions or other terms implied by statute or common law are hereby expressly excluded save to the extent they may not be lawfully excluded. When the Goods are sold to a consumer within the meaning of the Unfair Contract Terms Act 1977 their statutory rights are not affected by the provisions of this clause.
4. In the event of the Customer making a claim in respect of any defect in terms of clause 2 hereof the Customer must.
 1. Reasonably satisfy the Company that the Goods have been properly installed, commissioned, stored, serviced and used and without prejudice to the generality of the foregoing that any defect is not the direct or indirect result of lack of repair and/or servicing, incorrect repair and/or servicing, use of wrong materials and/or incorrect spare parts
 2. Allow the company to inspect the Goods and/or any installation and any relevant packaging as and when reasonably required by the Company.
5. Subject to the Company being notified of any defect as is referred to in sub-clause 2 hereof within a reasonable time of it becoming apparent and subject always to the terms of sub-clause 4 hereof, the Company shall, in its option, replace or repair the defective Goods or refund a proportionate part of the Price. The Company shall have no further liability to the Customer (save as mentioned in sub-clause 6 hereof).
6. The Company shall be liable to indemnify the Customer in respect of any claim for death or personal injury to any person in so far as such is attributable to the negligence or breach of duty of the Company or any failure by the Company to comply with the provisions of sub-clause 2 hereof.
7. Save as provided in sub-clause 2 hereof the Company shall not be liable in respect of any claim by the Customer for costs, damages, loss or expenses (whether direct, indirect, consequential or otherwise) or indemnity in any respect howsoever arising including, but not by way of limitation, liability arising in negligence (other than pursuant to clause 6 above) that may be suffered by the Customer or any third party.

Safety Notices

Symbols

This manual uses the following symbols to highlight specific areas important to the safe and proper use of the Generator

	A WARNING notice denotes a hazard. It calls attention to an operating procedure, process or similar, which if not correctly performed or adhered to, could cause personal injury or in the worst case death. Do not proceed beyond a WARNING notice until the indicated conditions are fully understood or met.
	A CAUTION notice denotes a hazard. It calls attention to an operating procedure, process or similar, which if not correctly performed or adhered to, could cause damage to the Generator or the Application. Do not proceed beyond a CAUTION notice until the indicated conditions are fully understood or met.
	Caution, risk of electric shock. Ensure power to the Generator has been removed before proceeding.

Safety Notice to Users



These instructions must be read thoroughly and understood before installation and operation of your Peak Genius 3070 Generator. Use of the Generator in a manner not specified by Peak Scientific MAY impair the SAFETY provided by the equipment.



When handling, operating or carrying out any maintenance, personnel must employ safe engineering practices and observe all relevant local health and safety requirements and regulations. The attention of UK users is drawn to the Health and Safety at Work Act 1974, and the Institute of Electrical Engineers regulations.

EU Declaration of Conformity

We Peak Scientific Instruments Ltd.
Of Fountain Crescent, Inchinnan, Renfrewshire, PA4 9RE

Hereby declare that, this declaration of conformity is issued under the sole responsibility of the manufacturer.

Equipment Type: Nitrogen & Dry Air Generator
Model Designator: Genius 3070

To which this declaration relates, is in conformity with the following applicable EU Directives, harmonized standards, and other normative requirements.

- **Low Voltage Directive 2014/35/EU**
EN 61010-1: 2010 Safety Requirements for Electrical Equipment for Measurement, Control and Laboratory Use.
- **Electromagnetic Compatibility Directive 2014/30/EU**
EN 61326-1: 2013 Electrical Equipment for Measurement, Control and Laboratory Use - EMC Requirements. (Class A)
- **Restriction on the use of certain hazardous substances in electronic equipment (RoHS) Directive 2011/65/EU as amended by EU 2015/863.**

Signed for and on behalf of Peak Scientific by

Signed:



Name: Fraser Dunn

Position: Design Engineering Manager
Peak Scientific Instruments Ltd,
Inchinnan, Renfrew, Scotland, PA4 9RE, UK.

Date: 10th August 2021



UK Declaration of Conformity

We Peak Scientific Instruments Ltd.
Of Fountain Crescent, Inchinnan, Renfrewshire, PA4 9RE

Hereby declare that, this declaration of conformity is issued under the sole responsibility of the manufacturer.

Equipment Type: Nitrogen & Dry Air Generator
Model Designator: Genius 3070

To which this declaration relates, is in conformity with the following applicable UK Statutory Instruments, Standards and other normative requirements.

- **The Electrical Equipment (Safety) Regulations 2016 (SI 2016 / 1101) as amended.**
BS61010-1:2010 Safety Requirements for Electrical Equipment for Measurement Control and Laboratory Use.
- **The Electromagnetic Compatibility Regulations 2016 (SI 2016 / 1091) as amended.**
BS61326-1:2013 Electrical Equipment for Measurement , Control and Laboratory Use - EMC Requirements.
- **The Restriction of the Use of Certain Hazardous Substances in Electrical and Electronic Equipment Regulations 2012 (SI 2012 / 3032) as amended.**

Signed for and on behalf of Peak Scientific by

Signed: 

Name: Fraser Dunn

Position: Design Engineering Manager
Peak Scientific Instruments Ltd,
Inchinnan, Renfrew, Scotland, PA4 9RE, UK.

Date: 10th August 2021



WEEE Compliance Statement

The Waste Electrical and Electronic Equipment (WEEE) Regulations SI 2013 No 3113 and or the Waste Electrical and Electronic Equipment (WEEE) Directive 2012/19/EU apply to all electrical and electronic equipment placed on the market in the UK and EU covered by the scope of regulations which can be found in the Government Guidance Notes (PDF) produced by the Department for Business Innovation and skills for the UK and here for Europe.

All PEAK products that are subject to the WEEE directive are compliant with the WEEE marking requirement. Such products are marked with the "crossed-out wheelie bin" symbol (shown below) in accordance with European standard EN50419. All old electrical equipment can be recycled. Please do not dispose of any electrical equipment (including those marked with this symbol) in general rubbish bins. Please contact your dealer or distributor for clarity.



Technical Specification

Environment

Minimum operating ambient temperature	5°C (41°F)
Maximum operating ambient temperature	35°C (95°F)
Maximum relative humidity	80% Non-Condensing
Maximum altitude	2000 meters
Minimum storage temperature*	-20°C (-4°F)
Maximum storage temperature*	60°C (140°F)

*NOTE - When taken out of storage the Generator should be allowed to acclimatize at room temperature for a minimum of 3 hours before operation.

Generator Outlets

Dry Air Maximum Flow (Nebulizer/Heating Gas)	34 L/min (1.2 cfm) @ 110psi (760kpa)
Air Maximum Flow (Exhaust)	31 L/min (1.1 cfm) @ 90psi (620kpa)
Particles	<0.01µm
Phthalates	NONE
Suspended liquids	NONE
Gas outlets	2 x ¼" BSPP
Drain outlet	1 x ¼" BSPP
Pressure gauges	2

Electrical Requirements

Voltage	230 VAC ± 10%
Frequency	50/60 Hz
Current	12 Amps
Input connection	C20 Plug
Power cord (Supplied)	C19 socket to local connection (13A minimum)
Pollution degree	2
Installation category	II

General

Dimensions in cm (inches) W x D x H	60 x 85 x 130.3 (23.6" x 33.5" x 51.29")
Weight	200 kg (441 lb)
Shipping weight	283 kg (628 lb)
Noise level	54 dBA @1m

Unpacking

Although Peak Scientific takes every precaution with safe transit and packaging, it is advisable to fully inspect the unit for any sign of transit damage.

Check 'SHOCKWATCH' label for signs of rough handling prior to un-packing –



Any damage should be reported immediately to the carrier and Peak Scientific or the Peak Partner from where the unit was purchased.

Follow the unpacking instructions posted on the side of the crate. It will require two people to remove the unit from the shipping crate and to manoeuvre the Generator onto the floor.

Please save the product packaging for storage or future shipment of the Generator.

Note: Included with the Generator is a "Fittings Kit" containing mains power leads for UK, EU and US also all the required fittings. Be careful not to discard these with the packaging.

Installation

Generator Environment



The Generator is designed for indoor use only. It should be installed adjacent to the application(s) it is supplying. If this is not convenient then the unit can be sited elsewhere, however, consideration should be made of the lengths of pipe runs as pressure drops can result from extended runs of pipe. Please see the [Tubing lengths](#) section for further details.



Performance of the Generator (like all sophisticated equipment) is affected by ambient conditions. Note should also be taken to the proximity of Air Conditioning outlets. These can sometimes give rise to “pockets” of air with high relative humidity. Operation of the unit within such a pocket could adversely affect its performance. Consideration should also be given to the air flow around the unit. It is recommended that an air gap of 75mm (3”) should be maintained down both sides, at the rear and across the top of the unit. Please refer to the drawing below for the general dimensions of the unit.

Maximum Ambient Conditions: 35°C (dry bulb) 80%RH (Max) Non-Condensing

General Dimensions

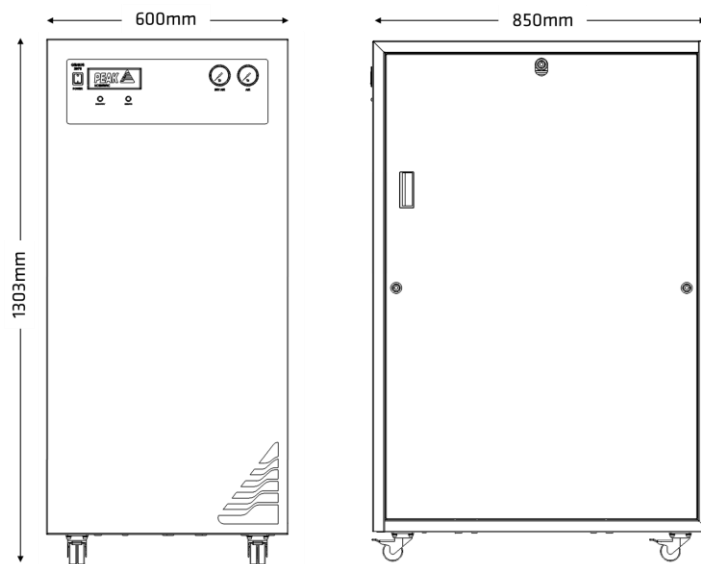

Figure 1 - General Dimensions



The Generator must always be placed on a level surface. Failure to do so will affect the performance of the Generator.

Fittings Kit

Supplied in the Fittings Kit are all the fittings required to connect the Genius 3070 Generator to the application. The contents of the Fittings Kit are as follows:

1. 8mm Hex Key	× 1	
2. 6mm Push Fit Tube Fitting	× 3	
3. ¼" Compression Tube Fitting		× 2
4. 6mm High Temp Tubing		× 4m
5. ¼" Teflon Tubing	× 6m	
6. 6mm Teflon Tubing	× 6m	
7. C19 Mains Cable (UK)	× 1	
8. C19 Mains Cable (Euro)		× 1
9. C19 Mains Cable (US)	× 1	
10. Silencer Fitting		× 2
11. Installation Guide - Genius 3070	× 1	
12. User Manual - Genius 3070	× 1	

All of the Generator output ports are located on the output panel at the rear of the Generator.

Removal of Transit Brackets



The transit brackets must be removed prior to switching the unit on. Failure to do so will result in damage to the equipment. This will void the warranty on the Generator and will result in a chargeable repair.

1. Using the 8mm hex key from the Fittings Kit, remove the side covers from the cabinet ensuring that earth cables are disconnected.
2. Remove the four screws with a #3 Pozidrive Screwdriver.
3. Slide the transit bracket out from under the compressor by pulling it towards you.
4. Repeat this for the compressor on the other side of the Generator.
5. Retain the transit brackets as these must be refitted if the Generator is to be transported again.

Note. Do not re-fit door panels in preparation for Voltage Check

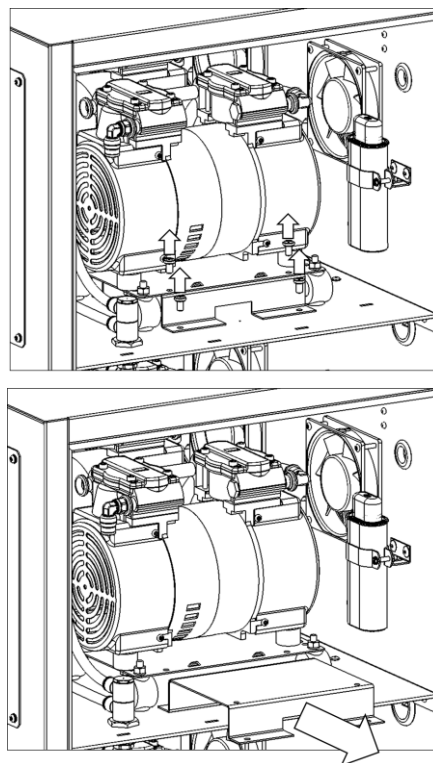

Figure 1: Transit Bracket Removal

Unit Controls

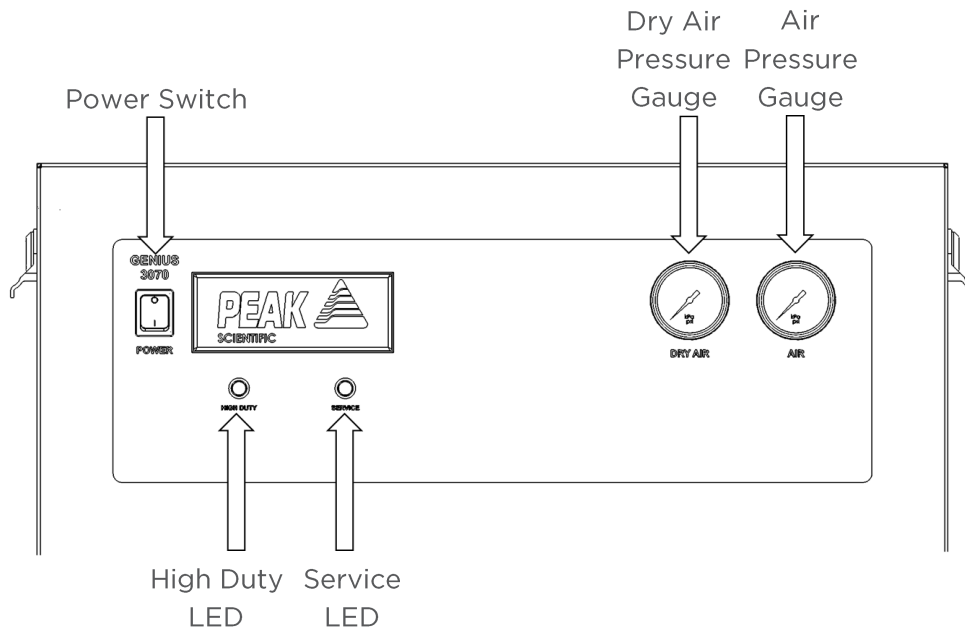

Figure 2: Unit controls

Rear Connections

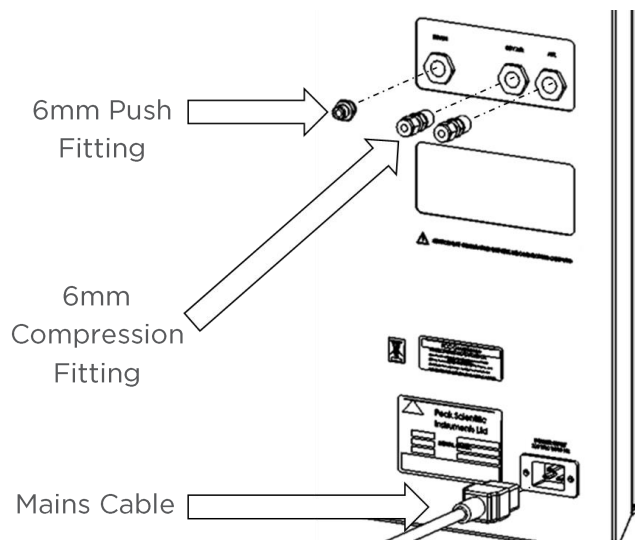

Figure 3: Rear Connections

Drain Connection

Fit the 6mm push fit fitting (item 2 from fittings kit) to the drain port located on the output panel. Tighten using a 16mm or 5/8" spanner. Use the 6mm tubing (item 4 from fittings kit) to connect this to a suitable drain connection or container. It should be noted that the Generator can expel a considerable amount of water from this (dependant on ambient humidity).



If a container is used it should be emptied at regular intervals. The container must NOT have an air tight seal as water and air are expelled at pressure.

Electrical Connection

Connect the Generator to a 230 volt single-phase supply using the power cord provided. If the appropriate power cord is not supplied; a new plug, rated to at least 12 amps, can be fitted by a qualified electrician.



This unit is classified as SAFETY CLASS 1. THIS UNIT MUST BE EARTHED. Before connecting the unit to the mains supply, please check the information on the serial plate. The mains supply must be of the stated AC voltage and frequency.

EARTH/GROUND (E):-	Green & Yellow	or	Green
LIVE (L):-	Brown	or	Black
Neutral (N):-	Blue	or	White

Our electrical requirements are 230VAC nominal +/- 10%. This means that the Generator can accommodate transients between 207VAC and 253VAC. However, running continuously at voltages less than 220V is not recommended and extended periods at these extremes can have a detrimental effect on the operation and life of the Generator.

To ensure that the correct voltage is being supplied to the Generator, the Genius 3070 comes equipped with an inbuilt voltmeter. This is located on the underside of the compressor compartment, Figure 4 below, and will measure and display the mains voltage that is being supplied to the Generator.

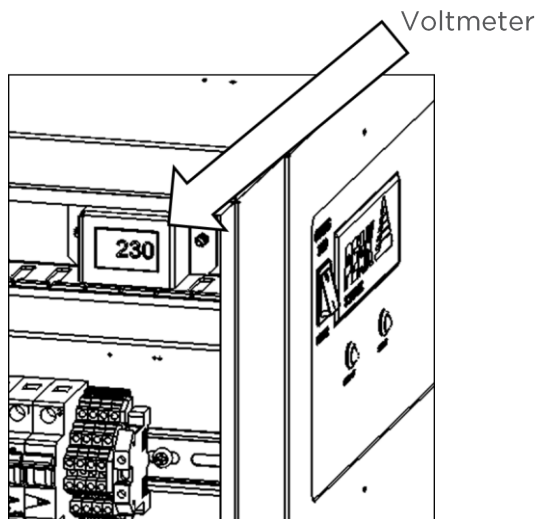

Figure 4: Voltmeter Location

The voltmeter should be checked prior to the initial purge of the system. To do this, with the doors remaining off and with the Generator still connected to the 230 volt single-phase supply, the unit should be powered ON using the power switch (identified by "I").



Do not touch anything inside the Generator whilst the side panels are removed and the mains power is connected to the unit

When the Generator is switched on, the input voltage will be displayed on the voltmeter. If this reading is 219V or less, then we would highly recommend fitting a transformer. This can be ordered directly from Peak Scientific with the order number being as below.

Product Description	Part Number
Dual Tap Transformer 200V - 230V	06-3210

Table 1: Additional Transformer

On completing the voltage check, the Generator should be powered OFF using the switch on the front panel, the power cord removed from the rear of the generator and the door panels refitted.



Ensure the Earth wires are reconnected to the side covers when refitting.

Initial Purge Run



Before the Generator is connected to the application, the Generator should be operated in isolation (i.e. not connected to the application) for thirty minutes. This is to ensure any impurities present are purged from the system. Failure to do this may harm the application.

Before re-connecting the Generator to the mains and switching it on for the isolation run, it is necessary to fit the silencer (supplied in the fittings kit) to the outlet ports of the output panel as shown below.

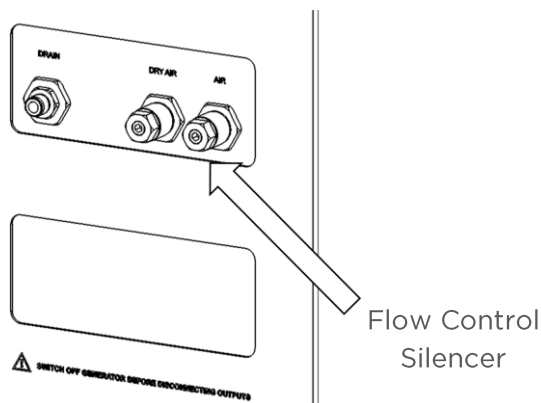

Figure 5: Fitting Silencer

Once this is done, the Generator can be re-connected to the mains and switched on.

Pressure will start to build in the internal storage tanks which can be monitored by watching the output pressure gauge on the front panel. This will climb to the factory set pressures as noted in the [specifications](#).

Once this pressure is reached, the compressors in each system will continue to run until the internal tanks upper pressure limit for that system is reached and the compressors have run for a period of at least two and a half minutes.

The compressors will then rest until the internal tank lower pressure limits is reached. Once this limit is reached the compressors will switch back on again. This compressor cycling is normal and will continue throughout the operation of the Generator.

When the systems have been operated for a period of 30 minutes, all the internal pipe-work and storage tanks will have been purged with Dry Air.

The Generator is now purged and the tubes can be connected at the rear of the unit.



Should a system be disconnected from its application, the 30 minute purge run must be performed on that system before re-connecting it to its specified application.

Connecting to the Application

Once the initial purge run of 30 minutes has completed the Generator is now ready to be connected to the application(s).



The pressure in the internal storage tanks must be allowed to dissipate before disconnecting the flow control silencer and connecting the Generator to the application(s)

Attach either the 6mm elbow or ¼” compression fittings to the outlets of the Generator. Using the 6mm or ¼” tubing supplied, connect the outlets of the Generator to the inlets on the application.

If you require more tubing than is supplied please refer to the [Tubing Lengths](#) section.



Once the tubing is connected to the application, please ensure that it is thoroughly checked for being leak-tight. Even the slightest leak in the gas supply between the Generator and the application can lead to a reduction in efficiency.

Tubing Lengths



The diameter of the tubing which will be connected to the gas outlet is important and is determined by the length of tubing required. Failure to follow these recommendations could lead to pressure between generator and application.

- | | |
|-------------------|---|
| < 10 meters: | Use 6/4 (6mm O/D, 4mm I/D) P.T.F.E. tubing. |
| > 10 - 40 meters: | Use 10/8 (10mm O/D, 8mm I/D). Tubing and fittings not supplied in the fittings kit. |
| > 40 metres: | Please contact Peak Scientific with the relevant distance and we will calculate the flow resistance and the tubing size required. |

A combination of 6/4 and 10/8 tubing may be used to ensure that there is no large diameter tubing within the lab (i.e. for the first 20 meters from the Generator use 10/8 and the final 10 meters to the application use 6/4 tubing). Keep the connections and bends to a minimum.

The imperial equivalents are: 6/4 = 1/4” O/D, 3/16” I/D.
10/8 = 3/8” O/D, 5/16” I/D.

IMPORTANT DOCUMENTS



Warranty Entitlement

To register your generator for your warranty entitlement, send the completed form to Peak Scientific by:

- *Email* warranty@peakscientific.com
- *Online* http://www.peakscientific.com/service-and-support/warranty_registration
- *Phone* +44 (0)141 530 4185
- *Fax* +44 (0)141 812 8200

PRODUCT WARRANTY REGISTRATION	
COMPANY:	CONTACT NAME:
ADDRESS:	
	EMAIL ADDRESS:
CITY/TOWN:	GENERATOR SERIAL NUMBER:
POSTCODE:	
COUNTRY:	MODEL TYPE:
TELEPHONE:	INSTALLATION DATE (DD/MM/YYYY):

Important Please Note:

You have 1 month to register your Peak Scientific product from the date of shipment.

If you wish to defer installation of your generator you must notify Peak Scientific within 1 month of the shipment date. This can be done by emailing warranty@peakscientific.com Once registered the warranty will be honoured for a period of 12 months after the installation date.

For any generators that remain unregistered the warranty will begin from date of shipment.

Thank you on behalf of Peak Scientific.

Normal Operation

The Genius 3070 Dry Air Generator is designed specifically to minimize operator involvement. Given that the system is installed as described in earlier sections and is serviced in accordance with the specified maintenance recommendations (see [Service Requirements](#)), then it should simply be a matter of turning the Generator on when it is required.

The Generator will automatically produce the factory set flow and pressure as detailed in the [Technical Specifications](#).

On Demand Air

The Generator produces air on demand. If the application is operating and requires an air flow, the system it is connected to will supply this to suit the requirements of the application. If the application requirement for air stops, the system will also stop, once it has reached its upper set limit in the internal storage tanks. If the demand from the application starts again, the system will detect the demand for air and will automatically start again to suit the demand.

Generator Cycling

The Generator and its individual systems are designed for the internal compressors to cycle. This cycling reduces the duty (run time) on the compressors. The rate at which they cycle will be dependent on the air required to satisfy the demand of the application. If the application demands the maximum air flow of the system, the compressor duty on that system will be higher, (the rest period in the compressor cycle will be shorter). If the application demand is lower than the maximum air flow, then the duty on the compressors will decrease, (the rest period in the compressor cycle will be longer). If the Generator is installed in an extreme environment or is subjected to low supply voltage or high altitude the compressors may undergo periods where they do not cycle (see [High Duty Indication](#)).

Unusual Operation

If at any time the Generator begins to emit excessive noise or vibration, then it should be switched off and you should contact Peak Scientific or the Peak Partner from which the Generator has been purchased.

Service Requirements

Service Schedule

Service Interval	Component	Part No.	Qty.
12 months	First stage filter element	00-0031	4
	Second stage filter element	00-0032	4
	Inlet filter element	02-1054	1
	Coalescing filter element	00-0032	1
	Activated Carbon Bag	02-5010	1
5000 hours	Compressor assembly	08-8316	1
Alternative to compressor assembly **	Compressor re-fit kit	06-8320	1

Table 2: Service schedule

** Compressors can be re-fitted as an alternative to replacement up to a maximum of 3 times, this is a more cost effective solution, however a degree of technical expertise is required and can be time consuming. Please contact your service provider for more information.

As an alternative to purchasing the 12 month service items individually an Annual Service Kit is available as one part number. This contains all the filters required for this Generator and offers a costs saving over buying the components separately.

Purchase Interval	Component	Part No.	Qty.
12 months	Genius 3070 Annual Service Kit	08-4788	1

Table 3: Annual Service Kit

Service Indication

The Genius 3070 counts the accumulative run-time (in hours) for the internal compressors. The Generator has the following Service Indication Stages for each system:-

Stage 1

Once either system reaches a total of 5000 run hours the service LED indicator (yellow) on the front of the Generator will illuminate. The screen located on the PLC will indicate which system and compressor(s) are due a service.

This is to make the user aware that a service of the system is due and should be planned at the earliest convenience. The Generator will continue to operate as normal with the LED on.



It is highly recommended that the compressors are serviced or replaced after 5000 run hours to prevent any unplanned downtime. Please contact your service provider for more information

Stage 2

If the service is not completed the Generator will continue to run. Once the system reaches a total of 5250 run hours, the service LED indicator (yellow) will start to flash. The screen located on the PLC will indicate which system and compressor are due a service.

This is to make the user aware that the service of the Generator is now overdue and must be completed immediately to ensure the continuous trouble free operation of the Generator.



Once 5250 hours is reached it is highly likely that the compressors will fail in the near future. Please contact your service provider as soon as possible to arrange a service or replacement of your compressors.

Service Indication Reset

Once the service has been completed the Service Indication LED can be reset in the main control PLC. This will be performed by the Peak Service Engineer or trained service representative that completes the service operation.

Service Plans

Peak Scientific offer two service plans. The Complete Service Plan, specifically designed for Generators operated in critical environments, also includes full breakdown cover, guaranteed response times and Generator upgrades if available. Our Standard Service Plan, covering the basic needs of our Generators, features special deals on spare parts and breakdowns.

If you want to know more about our Service Plan options and how we ensure that your instrument can run with the maximum uptime and performance, please contact us at maintenance@peakscientific.com

Cleaning

Clean the outside of the Generator only using warm soapy water and a clean damp cloth. Ensure the cloth is thoroughly rung out to remove excess fluid prior to use.



Cleaning should only be undertaken with the power switched off and the power cord removed from the rear of the Generator.



Under no circumstances should any solvents or abrasive cleaning solutions be used as these can contain fumes that could be harmful to the Generator.

High Duty Indication

The Genius 3070 has a 'HIGH DUTY' indicator on the front panel. This indicator monitors the running condition of the internal compressors of both systems and illuminates when they have been operating continually for a period of 8 hours.

There are a number of extreme conditions that can affect the duty cycling of the compressors inside the Genius 3070. These extremes include very high ambient temperatures, low supply voltages, a very high flow requirement and locations of high altitude. Any one of these or a combination of a number of these extremes can be evident in a customer site.

While the Genius 3070 Generator is designed to operate fully in these conditions it should be noted that the effect of these extremes can force the compressors to run continuously. The compressors are fully capable of running continuously with no detrimental effect. However it should be noted that if this is the case it will increase their duty and they will reach the 5000 hour recommended service interval quicker.

High Duty Indication Reset

If the compressors in either system have been operating continuously for a period of 8 hours the indicator light will be illuminated. Once the compressor(s) return to a cycling mode the indicator light will automatically switch off. There is no manual intervention required.

Indication of Fault



In most installations the 'HIGH DUTY' indicator will never be illuminated. If your Genius 3070 Generator has been operating for a significant period of time, then suddenly develops a 'HIGH DUTY' indication with no apparent change in environmental conditions or flow requirements, it may be indicative of a problem with the system such as an external leak or imminent compressor failure.

If this is the case you should contact Peak Scientific or your service provider.



It should be noted that the Generator will continue to operate so long as it can maintain pressure during this indication.

Trouble Shooting

Problem	Possible Solution
The Generator will not switch on and the power switch does not illuminate.	<ul style="list-style-type: none"> • Ensure power cord is plugged into the Generator and that the power socket is turned on. • Check the fuse in the power cord plug. • Contact your service provider. 
The Generator will not switch on but the power switch is illuminated.	<ul style="list-style-type: none"> • Disconnect power cord from the rear of the Generator. Open the left hand panel and check that both circuit breakers are turned on (switch in the up position). Reconnect power cord. • Contact your service provider. 
Compressors are running but pressure is not building.	<ul style="list-style-type: none"> • Contact your service provider.
The mass spec is reporting low pressure.	<ul style="list-style-type: none"> • Check pressure gauges are showing normal pressure. • Contact your service provider.
Yellow "SERVICE" LED on front panel is on constantly.	<ul style="list-style-type: none"> • A compressor(s) due for service. Contact your service provider. • Refer to Service Indication section of this manual for further information.
Yellow "SERVICE" LED on front panel is flashing.	<ul style="list-style-type: none"> • A compressor(s) is overdue for service. Contact your service provider urgently. • Refer to Service Indication section of this manual for further information.
Yellow "HIGH DUTY" LED on front panel is on constantly.	<ul style="list-style-type: none"> • A compressor(s) has not cycled for a period of 8 hours. Refer to the High Duty Indication section of this manual. • Ensure ambient temperatures are within the specification. • Ensure there are no leaks between the Generator and the mass spec.

Peak Scientific UK
Fountain Crescent
Inchinnan Business Park
Inchinnan
PA4 9RE
Scotland, UK
Tel: +44 (0)141 812 8100
Fax: +44 (0)141 812 8200

Peak Scientific North America
19 Sterling Road
Suite #1
Billerica, MA 01862
USA
Tel: +1 866 647 1649
Fax: +1 978 608 9503

Peak Scientific India
202, Amsri Shamira
Old Lancer Line
Opp. St. Mary's Degree College
S.D. Road Secunderabad
500 025, India
Tel: +91 40 2780 0663
Fax: +91 40 2780 0663

Peak Scientific Africa
PO Box 478
Somerset Mall
7137
South Africa
Tel: +27 (0)2185 16542
Fax: +27 (0)8654 64473

Peak Scientific Germany
Herriotstrasse 1
60528 Frankfurt

Germany
Tel: +49 (0)69 677 33 490
Fax: +49 (0)69 677 33 200

Peak Scientific China
Room 606 Building 1
Lane 2277 Zuchongzhi Road
Pudong New Area
Shanghai
201203, China
Tel: +86 21 5079 1190
Fax: +86 21 5079 1191

Peak Scientific Mexico
Solon 352
Col. Los Morales Polanco
11530 Mexico, D.F.
Mexico
Tel: +1 866 647 1649
Fax: +1 978 608 9503

Peak Scientific Australia
PO Box 65
Belmont
Victoria 3216
Australia
Tel: +61 1300 965 352

Peak Scientific Taiwan
4F.-6, No.736
Zhongzheng Rd.
Zhonghe Dist.
New Taipei City
Tel: +886 2 8226 2383
Fax: +886 2 8226 9499

Peak Scientific Brazil
Peak Scientific Brasil
Av. Quieroz Filho
1700 - torre Sunny-Conj. 602
São Paulo SP Brasil
Tel: +1 866 647 1649

Peak Scientific Japan K.K.
2-7-56, 2F Fuji Building 28
Kita Aoyama, Minato-Ku
Tokyo, Japan
107-0061
Tel: +81 3-6864-0468

Peak Scientific Singapore
3 Science Park Drive
#03-14 The Franklin
Science Park Drive 1
Singapore, 118223
Tel: +65-6777 1966
Fax: +65-6777 1978